

ECOWATER
S Y S T E M S[®]



Your Water. Perfected.

Let us

Perfect

your water and

Maximize

your peace of mind.

ESD2700

ECOWATER 2700 SERIES WATER SOFTENERS

The Latest Technology for Water Treatment

- 1 Patented Electronics Digital Demand Module**
Sophisticated, yet easy-to-use electronics capture historical usage patterns to predict future needs for precise regenerations.

Time Keeper

Permanent program memory with capacitor-backed time retention. Maintains time for at least 6 hours in case of power loss.

- 2 Multi-Wrap Fiberglass Reinforced Resin Tank**
Durable tank liner will not deteriorate, rust, or corrode.

- 3 Self-Cleaning Distributors**
Distributors exhibit excellent flow rates and are cleaned automatically by counter-current water pressure.

- 4 Positive-Action Brine Valve**
Snap-together construction eliminates use of solvents that may contaminate water. Positive action helps prevent overfilling.

Automatic Bypass During Regeneration Means Continuous Water Usage

Barium and Radium Reduction, and Low Lead Content

This softener has been tested and certified by NSF International against NSF/ANSI Standard 44 for the reduction of Barium and Radium 226/228, hardness reduction and efficiency and NSF/ANSI 372 for low lead content.

Energy Efficient Power Supply

Simplifies installation, maintenance and reduces electrical hazards.

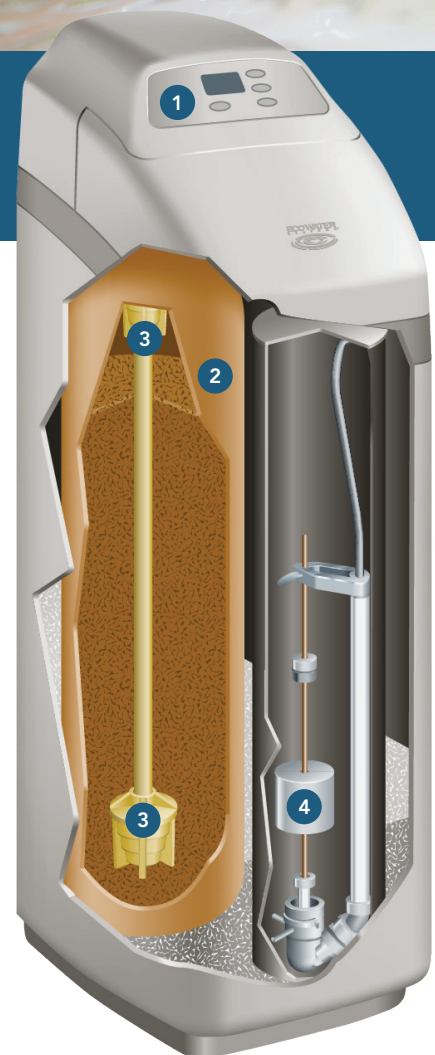

 Designed, Engineered & Assembled in the U.S.A.

ecowater.com

ESD2700

ECOWATER 2700 SERIES WATER SOFTENERS

DIMENSIONS

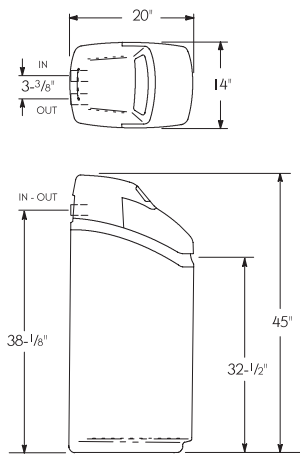

	ESD2700 R18	ESD2700 R25
Nominal Resin Tank Size	8" Diam. x 35"	10" Diam. x 35"

SPECIFICATIONS

	ESD2700R18	ESD2700R25
Efficiency (gr./lb. @ min. lb. salt dose)	5,030 @ 2.0	4,380 @ 3.48
Hardness Capacity (gr. @ max. lb. salt dose)	25,600 @ 10.7	33,000 @ 18.2
Certified Flow Rate (gpm @ psi)	5 @ 7.7	6 @ 8
Intermittent Flow Rate (gpm @ psi) ¹	7.5 @ 15	9 @ 15
Intermittent Flow Rate (gpm @ psi) ¹	11.3 @ 30	13.8 @ 30
Amount of Resin (lbs.)	35	59
Maximum Water Hardness (gpg @ 500 gpd water usage)	50	95
Maximum Clear Water Iron (ppm-Fe) ²	3	5
Approximate Water Used Each Regeneration (gal.) ³	29	41
Salt Storage Capacity (lbs.)	225	200
Supply Water Pressure Limits (psi) ⁴	20-125	20-125
Supply Water Temperature Limits (°F/°C)	40-120 / 4-49	40-120 / 4-49
Ambient Temperature Range (°F/°C)	35-150 / 2-66	35-150 / 2-66
Plumbing Connection Provided (inches)	3/4 and 1	3/4 and 1
Electrical Requirement, 120V, 50/60Hz, (24V DC, 500 mA, power supply included)		

¹Intermittent flow rate does not represent the maximum service flow rate used for determining the softener's rated capacity and efficiency. Continuous operation at flow rates greater than the certified flow rate may affect capacity and efficiency performance. The validity of these flow rates is verified by NSF. ²Increased amounts of clear water iron can reduce softener's efficiency. Refer to owner's manual for details. Wisconsin requires additional treatment if water supply contains greater than 5 ppm clear water iron. ³When operated at 35 psi water pressure. ⁴Maximum pressure for Canadian use is 7.0 Kg/cm².



Your Water. Perfected.

